

Late in 2009 Thomas Henry asked me if I wanted to do a beta test of his new approach to a CMOS 4046 based VCO. He and Scott Stites already had done some work on this project and I had the privilege to be the 1st “user” to build and try it.

As soon as I built it on breadboard I was stunned by the features, especially the hard sync: blew me away... Scott Stites did an awesome job on testing and to document the circuit, and you will find all the information necessary to set up and calibrate this VCO at his site:

[Birth Of A Synth \(Scott Stites\)](#)

This design uses the 4046 in a new way. It is certainly not the “perfect” VCO as you would call the CEM3340 a perfect VCO, nevertheless, it is an awesome VCO with a lot of character, while the tracking/scale is quite good. Thomas was able to get a very decent 8 octaves out of it:

CV (Volts)	Frequency (Hz)		Error	
	Predicted	Actual	in %	in Cents
0	20	19.5	-2.50%	-42.04
1	40	39.75	-0.63%	-10.51
2	80	80	0.00%	0
3	160	160	0.00%	0
4	320	320	0.00%	0
5	640	640	0.00%	0
6	1280	1281	0.08%	1.31
7	2560	2564	0.16%	2.63
8	5120	5122	0.04%	0.66
9	10240	10238	-0.02%	-0.33



Prototype, built with the new main PCB and the additional eurorack adapter PCB.

In the past I sold PCBs that were intended as prototyping PCBs to verify the VCO design. Now I made a new set of PCBs, consisting of the actual VCO PCB (now including the waveshaper), and an additional/optional Eurorack Adapter PCB for the front panel components. Both PCBs can be mounted piggy back using SIL connectors, so for Eurorack no manual wiring is needed.

Nevertheless, using the main PCB one could build this VCO for any format factor.

BOM & Building Notes

Qty	Value	Parts	Notes
Resistors			
2	10R/ferrite	F1, F2	
2	390R	R2, R3	
4	1k	R4-R7	
1	1.8k	R8	1K for 12V operation
1	2k	R9 (tempco)	PTC, +3500ppm/C
3	2.2k	R10-R12	
1	3k	R13	1K for 12V operation
1	4.7k	R14	
5	10k	R15-R19	R18, R19 = 15k for 12V operation
1	12k	R20	
1	18k	R21	
1	33k	R22	
3	75k	R24-R26	
9	100k	R27-R35	R32, R34 = 120k for 12V operation
2	120k	R48, R49	
2	220k	R0, R51	
1	330k	R52	390k for 12V operation
1	1.5M	R54	
1	2.2M	R55	
1	3.3M	R56	
1	100R	R1	Trimmer-S64Y/W
7	100k	R23, R36-R41	Trimmer-S64Y/W
Capacitors			
1	10n	C3 (timing cap)	Mica, NP0/COG or Polyesterene
6	10n	C4- C9	multilayer, 5mm
2	10uF	C12, C13	electrolytic, 2.5mm, 35V min
1	100pF	C1	film, 5mm
1	470pF	C2	film, 5mm
3	100n	C10, C120, C130	multilayer, 5mm
1	220n	C11	film, 5mm

Qty	Value	Parts	Notes
Semi's			
3	1N4148	D1-D3	
5	2N3904	Q1, Q2, Q3, Q6, Q7	
1	Q1 / Q2	LM394	matched pair to replace Q1, Q2
1	CD4046	IC1	National, Fairchild, Motorola, or NXP
1	LT1013	IC2	or TL072
2	TL074	IC3, IC4	
Off-Board (or Adapter PCB)			
1	SPDT on-off	S1	AC/DC
1	DPDT on-off	S2	LFO/VCO
6	100k	R42-R47	Potentiometer (9mm, snap-in)
1	500k or 1M	R53	Potentiometer (9mm, snap-in)
1	1uF NP	C_LFO	film cap, 5mm, non-polarized
1	LED	Bi-color LED	2-pin, 20mA, 3mm
1	470k	R_LED	adjust value to LED used
10	Jack	J1-J10	(Thonkiconn)
Misc			
1	IDE or MTA-156 power connector		
1	16-pol SIL female+male (Adaper PCB)		
1	10-pol SIL female+male (Adaper PCB)		
1	34-pol SIL female+male (Adapter PCB) 8+10+16 or file down/cut 2x16		

So here we go. The most crucial part is the CMOS 4046 phase lock loop IC itself. **You must not use a Texas Instrument or SGS Microelectronics branded 4046**, you won't be able to get the 1V/oct response.

I recommend the following:

NXP HEF4046, National CD4046, Fairchild CD4046, Motorola MC14046, or On Semiconductor MC14046.

Q1 and Q2 should be matched for better linearity. You could match them manually, or you could replace them by a super matched pair, i.e. the LM394 – if you still have one.

PCB Arrangement

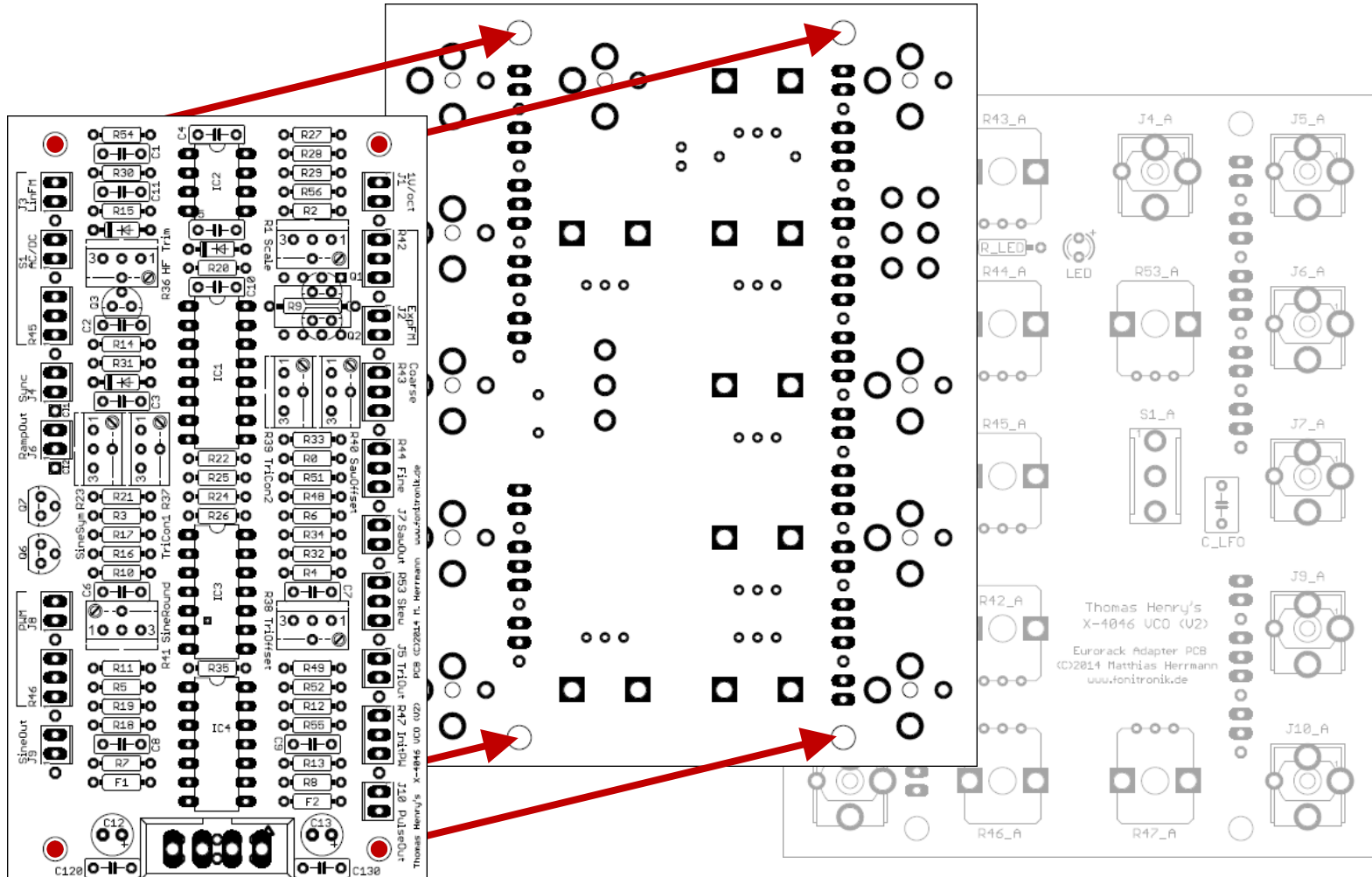

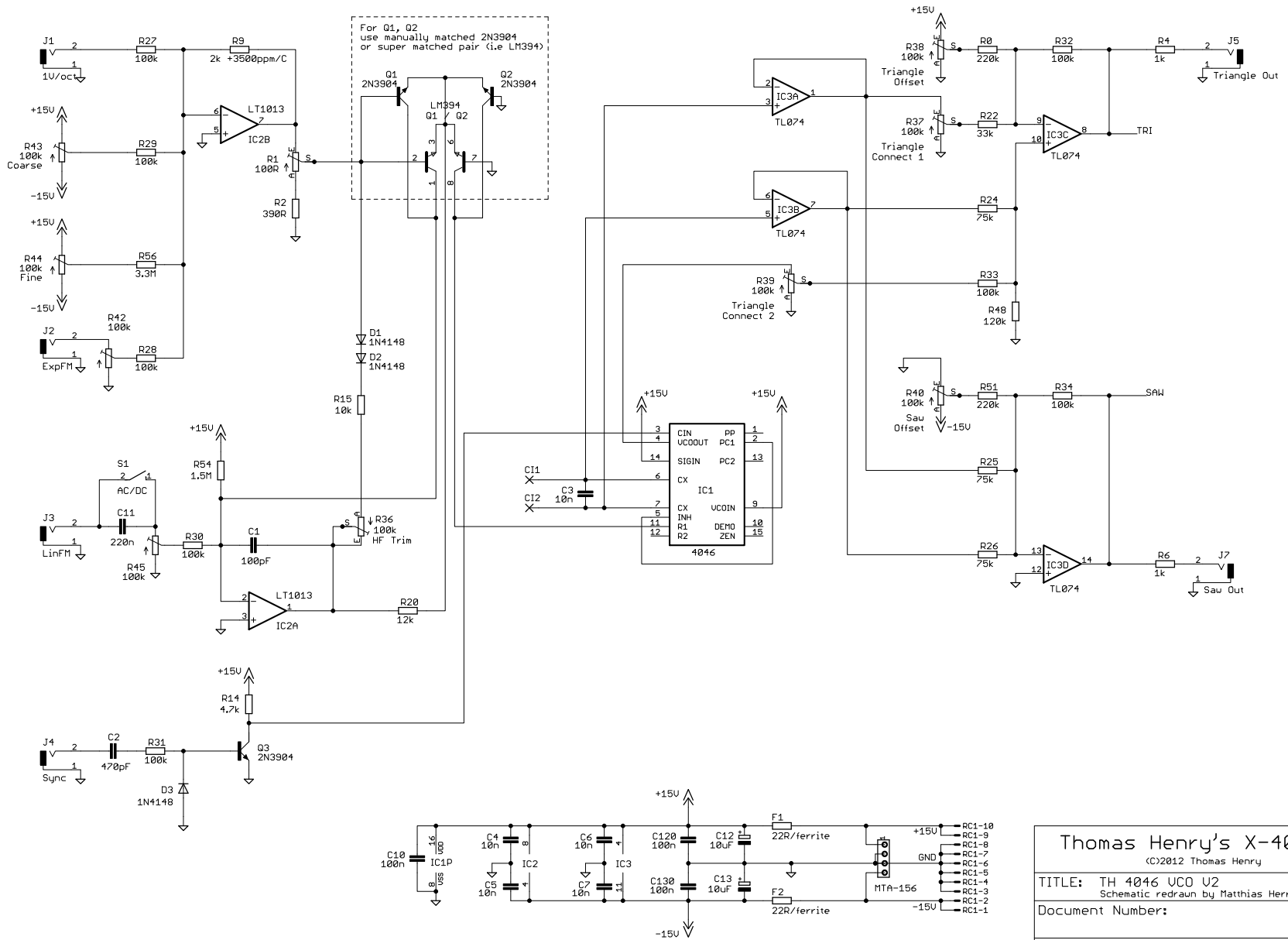

Thomas Henry's X-4046 VCO ©2012 Thomas Henry	
TITLE: TH 4046 VCO U2 Schematic redrawn by Matthias Herrmann	
Document Number:	REV: 1
Date: 8/6/2014 1:09:42 PM	Sheet: 1/2

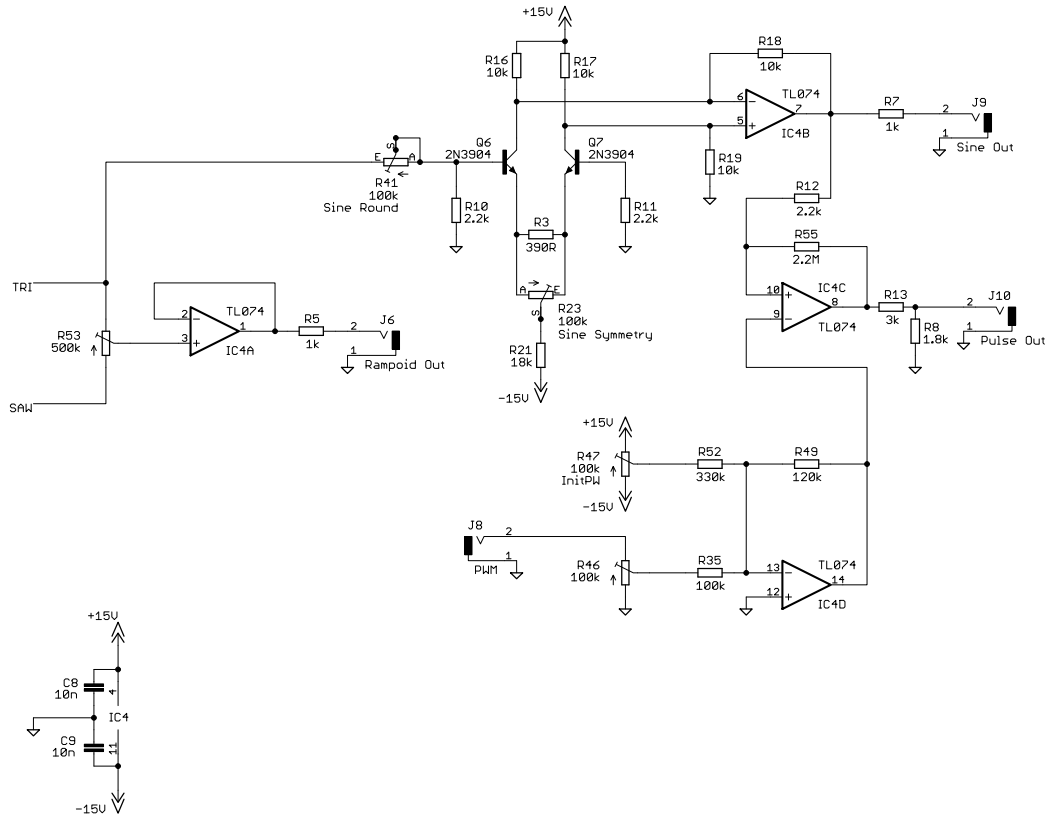

Thomas Henry's X-4046 VCO <small>(C)2012 Thomas Henry</small>	
TITLE: TH 4046 VCO V2 <small>Schematic redrawn by Matthias Herrmann</small>	
Document Number:	REV: 1
Date: 8/6/2014 1:09:42 PM	Sheet: 2/2